

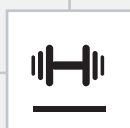

Original
werzalit®
Made in Germany
plus



Tischplatten | Table Tops

Technische Daten und Verarbeitungshinweise.

Technical data and processing instructions.

Fiche technique et conseils d'installation.

Especificaciones técnicas y instrucciones de tratamiento y uso.

Dati tecnici e istruzioni per la lavorazione.

Технические данные и инструкции по применению и обработке

werzalit®
BESTÄNDIG. SCHÖN.

Werzalit table tops are manufactured specially for use inside and outside using a patented procedure. Due to its high density material core manufactured from naturally grown wood and the surface pressed homogeneously with the wood material, Werzalit table tops are durable, hard-wearing and completely weather-proof. All Werzalit products are subjected to strict quality checks and tested for robustness and long-term weather resistance both in environmental chambers and natural weathering conditions in a wide range of climatic regions. Werzalit table tops come in a number of shapes, sizes and surface finishes, ranging from various standard decors to fabric covers and individual logos and motif prints. This variety makes Werzalit table tops the ideal furniture for gardens and recreation areas, as well as for professional catering furniture, trade fairs and events.

Original
werzalit®
 Made in Germany **plus**



Assembly of table frame

Due to the high density material, Werzalit table tops attain an extremely high screw extraction strength, allowing a simple, secure and particularly stable fixing between the table top and table frame. Standard joinery screws can be inserted without preliminary drilling and are sufficient for assembly. We recommend to use Spax screws 5 x ... If other screws are used, a hole corresponding to the core diameter should be drilled out of centre. The distance between the bore hole or tip of the

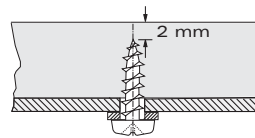

screw and the surface of the top should be at least 2 mm. In addition, the use of at least 2 screws per

foot should be planned for the individual fastening. The use of internal screw sockets made of steel or brass is also possible. These must be inserted with a dynamometric screwdriver and should have a hexagonal socket wherever

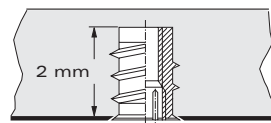

possible. Drilling is done with a core diameter or according to the manufacturer's specifications.

Recommended lengths: Max. 13 mm for M6 sockets, max. 14 mm for hole.

Preparation of sunshade hole

To facilitate the use of sunshades, Werzalit table tops can also be provided with integrated sunshade holes. If required, these can be supplied as special equipment, or they can be inserted retrospectively. In either case, the hole must always be fitted with a collar. For a crack-free and clean aperture, we recommend drilling on both sides, in the direction of both the underside and top side of the table.

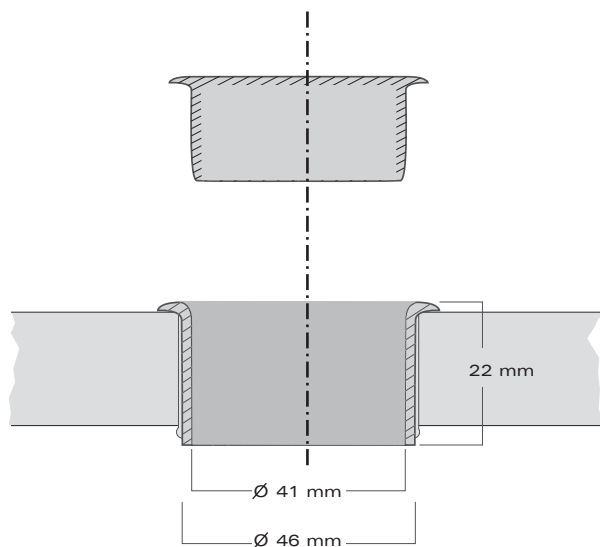

Relative surface heating depending on the decors.

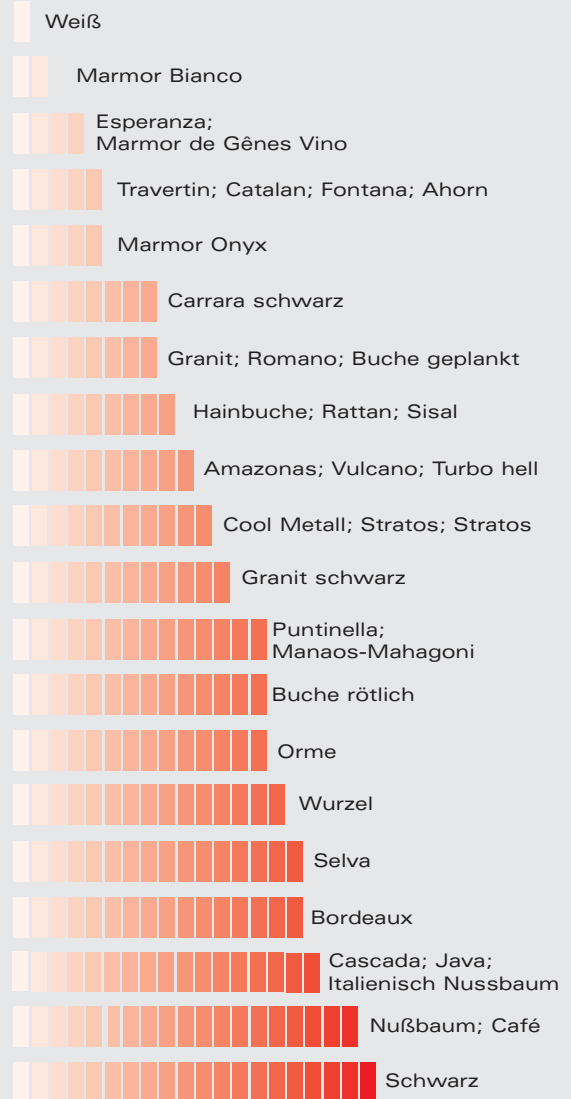

**Werzalit – wood on the inside,
strong on the outside.**

Only freshly cut wood from domestic deciduous and coniferous trees is used to manufacture Werzalit table tops.

Finely chipped and with the addition of special resin, the material Werzalit is produced under heat and high pressure. In addition to its weatherproof properties and resistance to moisture, it also has a particularly high degree of dimensional stability. Nevertheless, particularly dark decors can absorb heat of up to 70 °C during exposure to direct sunlight, resulting for example in a change to the optically plane surface if the tables are not sufficiently supported by a frame. Although this concave distortion is reversed by itself as the exposure to sunlight recedes and temperatures drop, Werzalit table tops have a basic convex form up to 3 mm/m, although remaining deformation of up to ± 4 mm/m lies within the permissible tolerances. Irrespective of this, the stability and perfect function of Werzalit table tops are ensured at all times. The observance of a few simple rules will therefore serve primarily as a preventative measure and also guarantee a perfect look for a number of years. A choice of extremely light to no more than

We therefore recommend:

 medium-dark shades for decors, particularly for external areas. Unlike darker decors, they reflect the light and considerably reduce surface warming. In addition, they have a positive effect on the atmosphere for your guests. The diagrams given in this brochure provide an overview of the degree of heat absorption of individual decors.

With table tops with dark decors in unprotected areas with sustained exposure to intensive sunlight, greater attention must be paid to the use of high-quality table frames. They not only increase the visual charm, but also support and stabilise the bending forces. Four-leg frames should always be given precedence over three-leg frames due to the firmer support that this provides. If necessary, the reinforcement of existing table frames can be increased at any time through modification of retrospectively assembled rails or mounting plates. (see also the drawings on page 26)

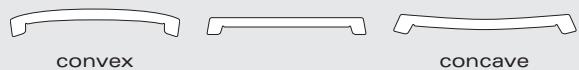

Technical data for original Werzalit Plus table tops

Properties	Value and unit	Test method
Density	700 - 800 kg/m ³	EN 323
Bending strength	30 - 50 N/mm ²	EN 310
E-module	4000 - 6000 N/mm ²	EN 310
Toughness under impact	10 - 12 kJ/m ²	DIN 52189
Thickness swell following storage in water (measured on 25 mm-wide test pieces) ²		
V-100 swelling (2h storage in water at up to 100°)	Edge ≤ 10,0 % area ≤ 12,0 %	EN 317
V-70 swelling (5h storage in water at up to 70°)	Edge ≤ 6,0 % area ≤ 9,0 %	Werzalit Test Standard ²
V-20 swelling (2h storage in water at up to 20°)	Edge ≤ 0,5 % area ≤ 1,0 %	
Rising height	≤ 20 mm	Werzalit Test Standard
Following 16 hours Burchell immersion test	No cracks or bubbles are permissible on assessment after 1 hour.	
Screw extraction strength (4mm particle board screws, screwed in 10 mm)	800 - 1300 N	Werzalit Test Standard
Surface quality: abrasion-resistant, resistant to cigarette ash, resistant to all household cleaning agents and solvents, stain-resistant, resistant to diluted acids and alkaline solutions.		EN 438
Surface stability/telegraphing	Good/low, coarse chippings not permitted on surface. (Determined by limit sample)	
Hardening of coating (acid test with 0.1 n hydrochloric acid)	1 - 2	
Scratch resistance of surface	3,0 - 5,5 N (scratch resistant)	EN 438
Brinell hardness of surface	60 - 65 N/mm ²	Werzalit Test Standard ⁽¹⁾
Resistant to hot saucepan bottoms (20 min at 180°C)		EN 438
Sensitivity to light of surface, dependent on decor	Grade 6 - 8*	DIN 54004
Temperature resistance	Freeze-proof and heat-resistant (-50°C bis + 90°C)	Werzalit Test Standard

The table tops conform to the low emission class "E1".
Requirements specified in Appendix I of the Ordinance on the Ban of Chemicals V

*8 is the highest possible grade for sensitivity to light. ⁽¹⁾1000 N, 15 s Rest period, (Force / impression area).

Vorschläge zur Verstärkung von Tischplatten | Suggestions for reinforcing table tops
 Solutions pour stabiliser des plateaux de tables | Propuestas para el refuerzo de tableros
 Accessori raccomandati per rinforzare il piano del tavolo | Предложения по укреплению столешниц

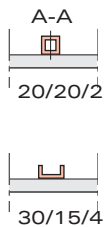
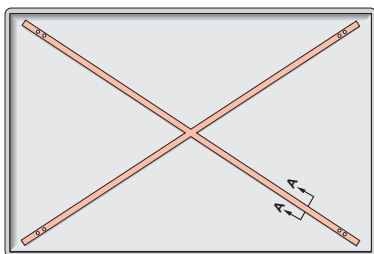

Diagonal verschweißtes Stahlkreuz aus Quadrat oder U-Profil.
 Diagonally bonded steel cross made of a quadrant or U section.
 Croix diagonale, en profilés métalliques carrés ou en U.
 Estructura cruzada de acero soldado de forma diagonal en perfil cuadrado o en U.
 Croce in acciaio saldata in diagonale quadra o con profilo a U.
 Диагонально приваренная стальная крестовина из квадратного или U-профиля.

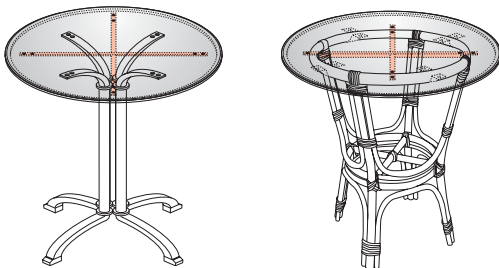

Verschweißtes Stahlkreuz aus Quadrat oder U-Profil.
 Bonded steel cross made of a quadrant or U section.
 Croix métallique en profilés carrés ou en U.
 Estructura cruzada de acero soldado de perfil cuadrado o en U.
 Croce in acciaio saldata quadra o con profilo a U.
 Приваренная стальная крестовина из квадратного или U-профиля.

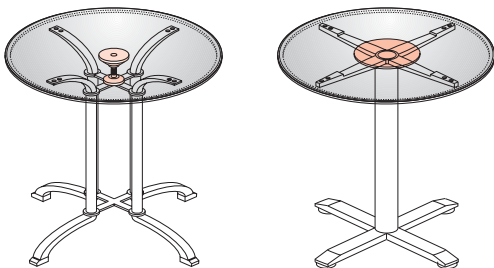

Unterstützung mittig mit Gewindespindel oder Distanzplatte.
 Centre support from a threaded spindle or distance plate
 Support au centre avec tige filetée ou platine entretoise.
 Soporte central con husillo roscado o placa distanciadora.
 Supporto al centro con asta filettata o distanziale.
 Поддержка по центру с помощью ходового винта или дистанционной пластины.

Werzalit AG + Co. KG

Postfach 20

71718 Oberstenfeld

Telefon: +49(0)7062/50-272

Telefax: +49(0)7062/50-321

info@werzalit.de

www.werzalit.de

Export

Telefon: +49(0)7062/50-180

Telefax: +49(0)7062/8665

info@werzalit.de

werzalit[®]
BESTÄNDIG. SCHÖN.